

Profile

- Freely programmable electronic digital display for length or angular measurement
- Hollow shaft, max. \varnothing 30 mm
- LCD display with 5 digits and special characters
- Digit height approx. 12 mm
- Reset, incremental measurement, offset via keyboard
- Long battery life
- Easy battery change without dismantling of the device

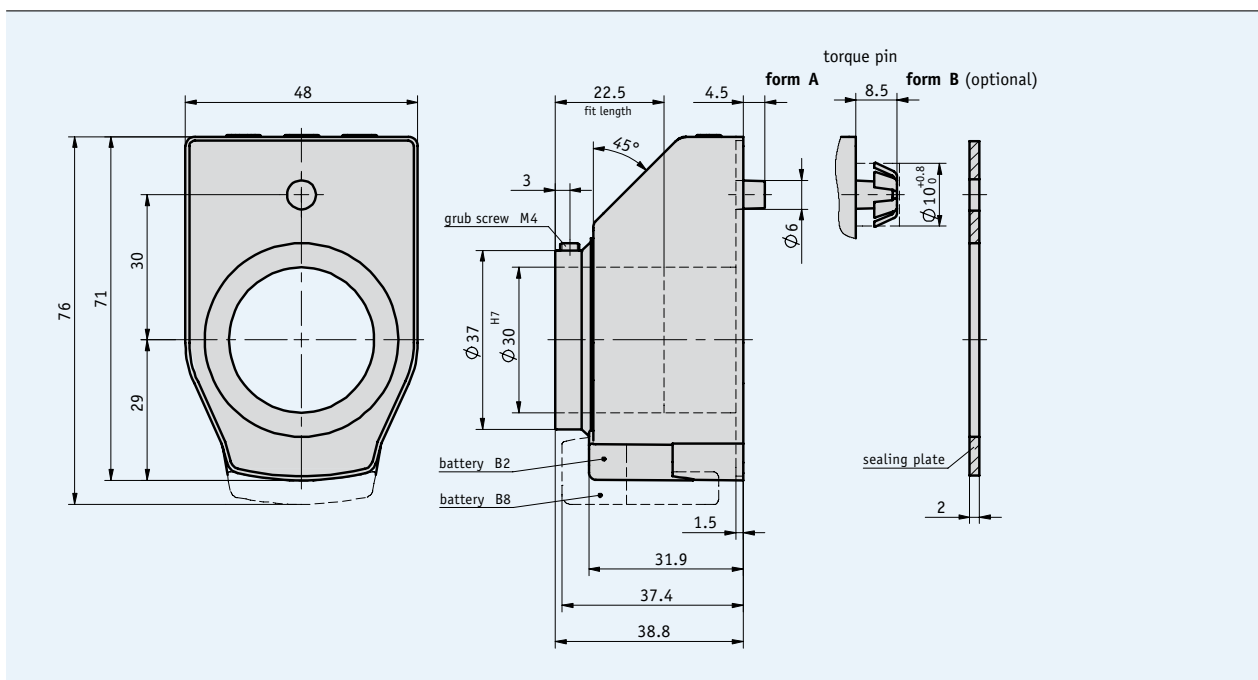

1.2

Mechanical data

Feature	Technical data	Additional information
Weight	approx. 0.1 kg	
Hollow shaft	\varnothing 30H7, plain bearing, browned steel	
Rotational speed	max. 600 rpm (100 % operation time)	
Protection category	IP51	
Operating temperature	-10 ... +60 °C	
Storage temperature	-30 ... +80 °C	
Housing	plastic	
Shock resistance	30 g / 15 ms	according to DIN EN 60068-2-27
Vibration resistance	10 g / (5 ... 150 Hz)	according to DIN EN 60068-2-6
	20 g / (100 ... 2.000 Hz)	according to DIN EN 60068-2-6

Electrical data

Feature	Technical data	Additional information
Display	LCD display, 5-digit, 11.5 mm digit height	
Display range	-19999 ... 99999	
Battery	lithium coin cell, 3 V, CR2032 type	~2 years of service life
	lithium coin cell, 3 V, CR2477 type	~8 years of service life
EMC	DIN EN 61000-4-2	
	DIN EN 61000-4-4	

Order

Order note

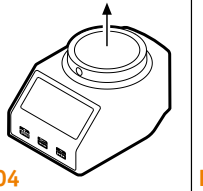
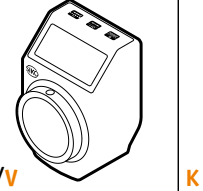
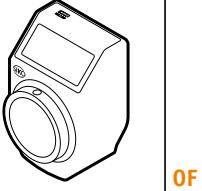
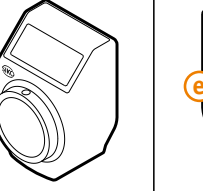
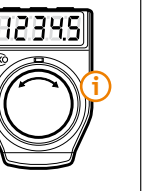
Mounting position		Key pad operation			Counting direction
					
02	04	D/V	K	OF	

Note: Characters highlighted in orange are order features

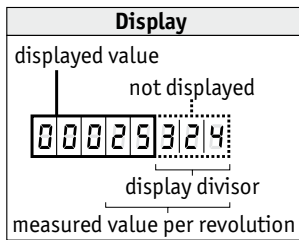

Display divisor

The indication of the measured value on the display can be influenced by means of the divisor (divider). The divisor shifts figures of the measured value into the invisible sector of the display unit. Although the figures are not displayed, they are also calculated by the electronics unit and mathematically rounded.

Calculation of value displayed (example: order text):

Measured value per revolution 25324
 Display divisor 1000

Feature	Value displayed	Measured value
1 st revolution	25	25324
2 nd revolution	51	50648
3 rd revolution	76	75972

Order table

Feature	Order text	Specification	Additional information
Design/mounting position*	02	horizontal spindle	
	04	vertical spindle	
Measured value per revolution*	...	2 ... 90 000	see calculation of value displayed
	W3600	angular mode 0 ... 360°, resolution 0.1°	only for decimal point „1“
	Z3600	angular mode -180 ... +180°, resolution 0.1°	only for decimal point „1“
Decimal place*	0	0 = 00000	
	1	1 = 0000.0	
	2	2 = 000.00	
	3	3 = 00.000	
Display divisor*	...	1, 10, 100, 1000	see calculation of value displayed
Counting direction* = ascending values	i	clockwise	
	e	counter-clockwise	
Key pad operation	D	zero setting, directly*	
	V	zero setting, delayed by 5 s*	
	K	only incremental measurement key	
	OF	without function keys	
Hollow shaft/diameter (mm)	30	∅ 30 mm	
	...	RH16, RH20, RH24, RH25, RH26	reducing bushes
		others on request	
Color	0	orange RAL 2004	
	R	red RAL 3000	
	S	black RAL 9005	
Battery	B2	~2 years of service life	
	B8	~8 years of service life	pay attention to the technical drawing

* programmable by means of ProTool DE programming software

Order code

DE10 - - - - - - - - - - - -

A B C D E F G H A I

Scope of delivery: DE10, User information

Accessories:

Programming software ProTool DE
Reducing bushes

Page 107
Page 108

Additional information:

General information and areas of application

Page 30 cont.